

## COMPREHENSION AND APPLICABILITY OF LCA/LCM PHILOSOPHY – ONE OF THE CRITERIA FOR BETTER COMPETITIVENESS

Predrag Cosic, Goran Djukic, Marko Karasic  
University of Zagreb, Faculty of Mechanical Engineering and Naval Architecture  
Ivana Lucica 5, 10 000 Zagreb, Croatia, <http://ptp.fsb.hr;predrag.cosic@fsb.hr>

### ABSTRACT

*Total environmental impact in some areas will still rise as a consequence of the growing flow of products and the activities to which they are leading. LCA approach include different tools for implementation through process planning: ISO standards 14040-series, IPPC directive, national legislative, influence of state/non-state organizations, mass media, etc. Described case study and used LCA application and eco indicator method can be useful for more complex environmental analysis of product influence.*

**Keywords:** eco indicator, life cycle assessment, clean production

### 1. INTRODUCTION

Even if the biggest individual emissions are reduced, the total environmental impact in some areas will still rise as a consequence of the growing flow of products and the activities to which they are leading. For better SME competitiveness we need different approaches. LCA approach as one of them, include different tools for possibly implementation through process of product design and process planning by help: ISO standards 14040-series, IPPC directive, national legislative, influence of state/non-state organizations, mass media, etc. Our aim is to investigate point of views SME, ecological consulting companies, in view of LCA importance through developed questionnaire, LCA case studies, etc. One of these first steps in this research would be presented here.

### 2. ECO INDICATOR, CLEANER PRODUCTION, LIFE CYCLE ASSESSMENT AND MANAGEMENT (LCM/LCM)

Designers make decisions that influence the environment during the product's life cycle. So, designers use ten guidelines for ecodesign [1] (for example, "Do not design products, but life cycles, Natural materials are not always better, Energy consumption, Increase product life time, Do not design products, but services"), etc.

The *Eco-indicator method* can only be used in the creative and conceptual phases of the design process. The method is also the basis for the calculation of eco-indicator scores for materials and processes. On the other side, *Cleaner Production* is a 'win-win' strategy. It protects the environment, the consumer and the worker while improving industrial efficiency, profitability, and competitiveness. For products, Cleaner Production aims to reduce the environmental, health and safety impacts of products over their entire life cycles, from raw materials extraction, through manufacturing and use, to the 'ultimate' disposal of the product. Products themselves do not pollute: it is the factories that made them, the trucks that transported them, the user who uses them and the incinerator that burns them. So, Life Cycle Assessment (LCA) models the complex interaction between a product and the environment "from cradle to grave". It is also known as Life Cycle Analysis or Ecobalance.

**Life Cycle Management** is all about making more informed business decisions - and chances are that life cycle considerations are already influencing the decisions you are currently making in your business on a daily basis, such as those listed below: Which products to manufacture?, Design of the

product or service, How can LCA approach can be useful in company competitiveness ?, etc. Life Cycle Management is not interchangeable with Life Cycle Assessment (LCA).

**Life Cycle Assessment (LCA)** is a specific method for systematically identifying, quantifying and assessing inputs and outputs (i.e. sources of environmental impact) throughout a product or service's life cycle. It is one of a range of tools that support Life Cycle Management, but does not have to be part of adopting Life Cycle Management.

### 3. LCA OF BICYCLE FRAME PRODUCTION - CASE STUDY

In SETAC's Code of Practice, it is recommended that the LCA be split into five stages: planning, screening, data collection and data treatment, evaluation and improvement assessment.

It is generally recognized that the first stage is extremely important. The result of the LCA is heavily dependent on the decisions taken in this phase.

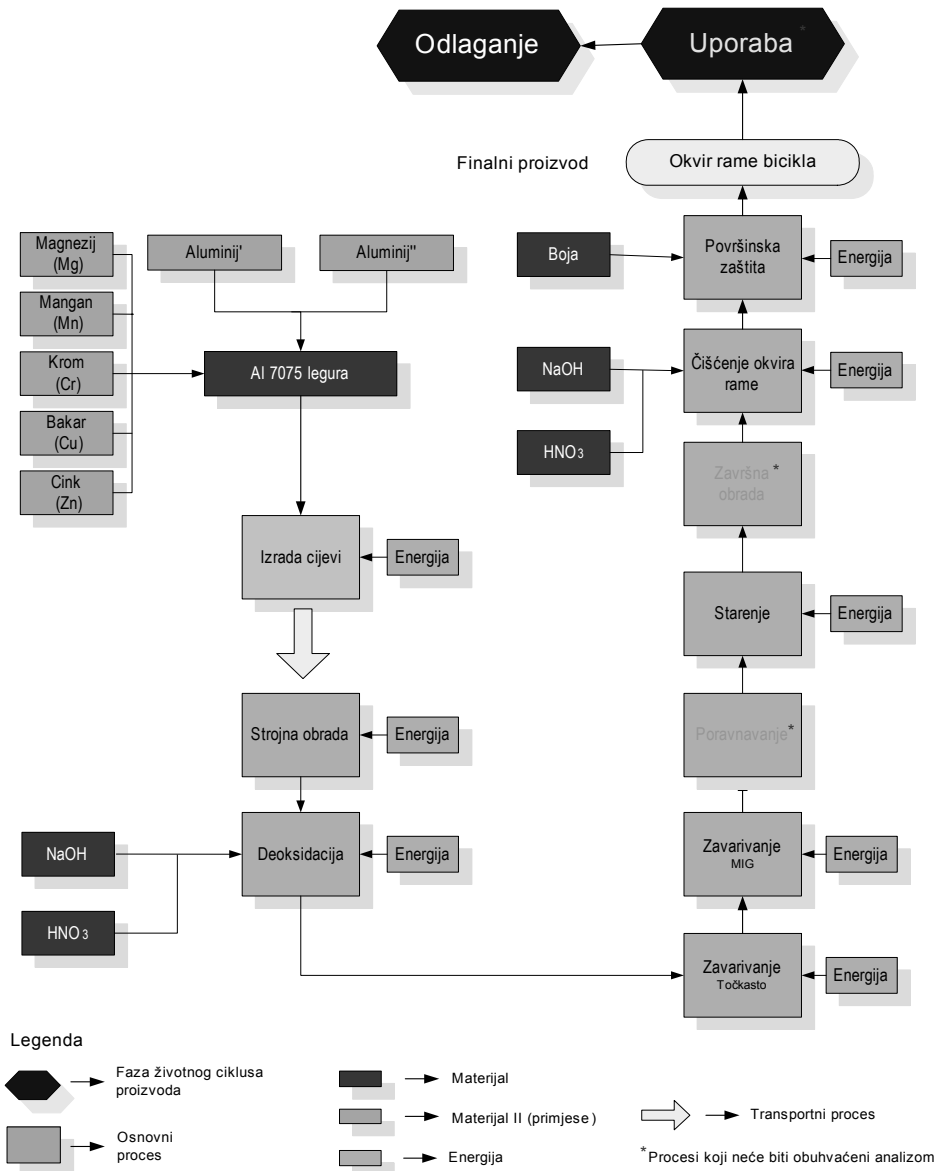

Figure 1. Estimation of influence potentials for some environmental emissions of case study [8]

So, in Life Cycle Inventory step, the basis of LCA is the creation of a model that contains the amounts of all inputs and outputs of processes that occur during the life cycle of a product. This includes the production phase, distribution, use and final disposal of the product. To avoid we need to

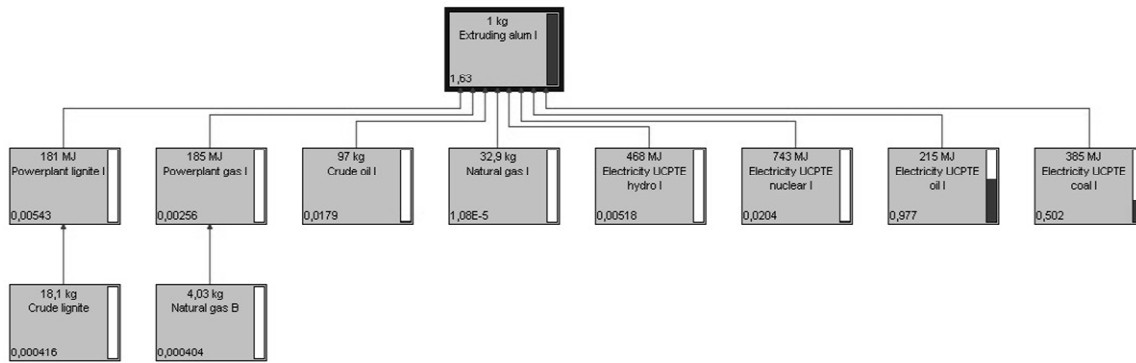

Figure 2. Process tree considered process of tube extrusion [8]

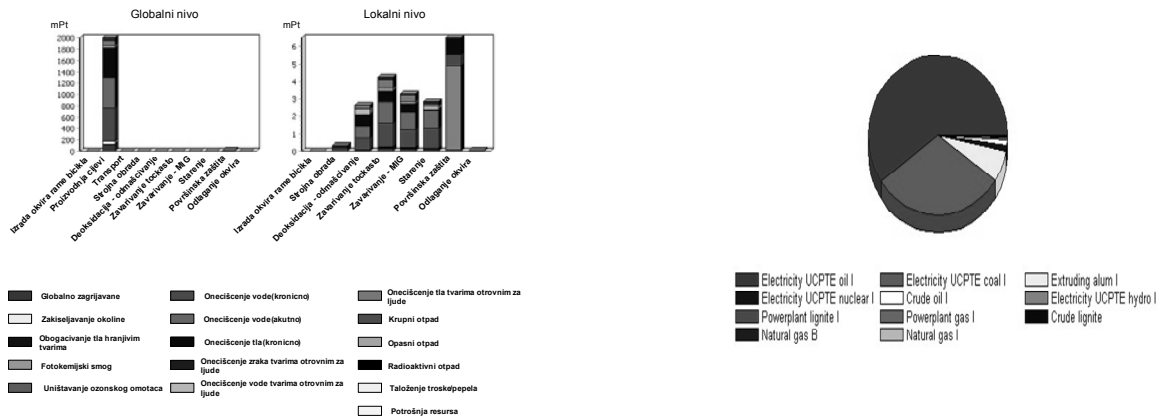

Figure 3. Diagram presentation of total environmental influence of some processes [8]

Figure 4. Portion of total environmental contamination some subprocesses in observed process of Al alloy extrusion [8]

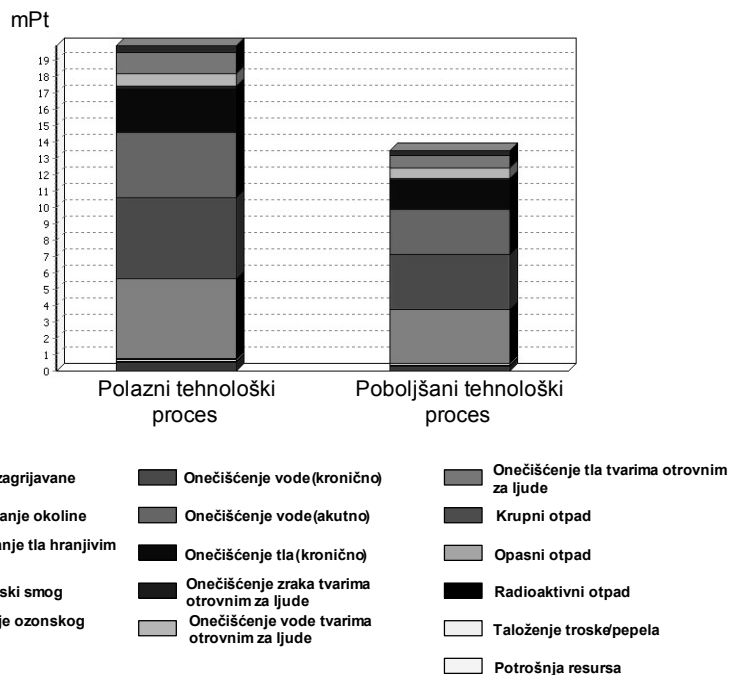

Figure 5. Comparison of the initial and improved technological processes [8]

collect too much data, we need to set boundaries ( *Figure 1*). By use an analytical approach for determining the environmental impact (for bicycle frame [7]) of observed processes and materials we can, with defined boundaries and restrictions in accessible knowledge database [2, 3, 4] (in version of application SimaPro 7) [5] get screening results as the good basis for deeper analysis.

With information about each process and a process tree (*Figure 2*) of the life cycle inventory of all the environmental inputs and outputs associated with the product – selected tube is the most important part with processes (*Figure 3 and Figure 4*). The result is called *table of impacts*. CML and SETAC describe a general approach, through the calculation of environmental effects. There are three steps: classification and characterization, normalization and evaluation or weighting [1].

Analysis of results gives us results from two points of views: local and global (*Figure 3*). So, with comparison these results it can be observed that production of Al alloys tubes by process of extrusion has the most important influence in the global level of environment. On the side, surface protection of the bicycle frame (*Figure 3*) has the most important environmental influence on the local level of environment. Potential benefits of this simplified approach (more complex approach must include more extensive database of processes and materials, more experts, developed company network, more rich financial support, and last but not the least, more research time) at this level of research can only suggest measures for improvement of the frame production at local level (*Figure 5*). Processes of surface protection and point welding would be critical points in production process. For example, process of surface protection can be improved by use paint on natural basis and deposition of thinner layer of paint. Or, in process of welding by using special jig we can avoid process of spot welding (*Figure 5*).

#### 4. CONCLUSION

Potential benefits of this simplified approach (more complex approach must include more extensive database of processes and materials, more experts, etc) at this level of research can suggest measures for improvement of the frame production at local level.

#### 5. ACKNOWLEDGMENT

This research is a part of the scientific projects (2007-2009) titled *Process Production Impacts to the Competitive and Sustainable Development* 120-1521781-3116 financed by the Ministry of Science and Technology of the Republic of Croatia and bilateral scientific project supported by Slovenia-Croatia Cooperation in Science and Technology, (2007-2008) named *Virtual Manufacturing – Step to Captivity and Sustainable Development* financed by the Ministry of Science, Education and Sport of the Republic of Croatia and Slovenian Research Agency (ARSS). We express gratitude for the financial support for these projects.

#### 6. REFERENCES

- [1] Jeroen B. Guinée, Marieke Gorrée, at all, Life Cycle Assessment, An Operational Guide to the ISO Standards, Final Report of project, May 2001.
- [2] Munoz, A., A., Sheng, P., An analytical approach for determining the environmental impact of machining process, *Journal of Materials Processing Technology* 53 (1995) pp. 736 – 758.
- [3] Bockermann A., Meyer B., Omann, I., Spangenberg, J., H., Modelling sustainability Comparing an econometric (PANTA RHEI) and a systems dynamics model (SuE), *Journal of Policy Modeling* 27(2005) pp. 189-210.
- [4] Grubbs, G., H., Frace, S., E., Bouwes, N., Economic and Environmental Benefits Analysis Document For The Final Effluent Limitations, Guidelines and Standards For the Metal Products & Machinery, U.S. Environmental Protection Agency, Washington, DC 20460, February 2003.
- [5] Goedkoop, M., Schryver, M., Oele, SimaPro7, - Introduction to LCA with SimaPro, PRé Consultants, March 2006.
- [6] Choi, A., C., K., Kaebernick., H., Lai, W., H., Manufacturing process modelling for environmental impact assessment, *Journal of Materials Processing Technology*, 70(1997), pp. 231 – 238.
- [7] P. Cosic, Distributed production – Step to the Competiveness, The 17th International DAAAM Symposium, "Intelligent Manufacturing & Automation: Focus on Mechatronics & Robotics", Vienna, Austria, 8-11th November 2006, pp
- [8] Karasic, M., Graduated work named "Influence of the estimation life cycle assessment in process planning of product", University of Zagreb, FSB, March, Zagreb, 2007.