

## THE DESIGN AND SIMULATION OF TRAINING DELTA ROBOT

Viera Poppeova  
University of Žilina  
010 26 Žilina  
Slovakia

Rudolf Rejda  
University of Žilina  
010 26 Žilina  
Slovakia

Juraj Uricek  
University of Žilina  
010 26 Žilina  
Slovakia

Vladimir Bulej  
University of Žilina  
010 26 Žilina  
Slovakia

### ABSTRACT

*This paper informs about the development of training delta robot Caertec rk 2010 at University of Zilina. Parallel kinematics of robot is based on three parallelogram mechanisms. Kinematic loops of Delta robot were counted by the inverse kinematics. For delta robot control and trajectory programming was developed software. The program allows the simulation, the workspace analysis, the positions programming and the communication management. The structural design and simulation has been developed using system CATIA.*

**Keywords:** parallel kinematic structure, parallel robots, delta robots, inverse kinematic analysis, simulation software

### 1. INTRODUCTION

The parallel kinematic structure is a closed-loop kinematic chain mechanism whose end-effector is linked to the base by several independent kinematic chains.

Parallel structures are interesting due to their large stiffness and high positioning accuracy compared to serial robots. This kind of kinematic structure can be used in many fields but most of them are used as robots or as numerical controlled machine tools. Specific applications such as spatial, medical, joysticks and simulators are also possible.

Parallel robots can also be defined as: a parallel robot is made up of a fixed base and of an end-effector with n-degrees of freedom that are linked together by at least two independent kinematic chains. Actuation takes places through n-simple actuators. This type of mechanism is interesting because when the actuators are locked, the manipulator remains in its position (this is an important safety aspect), and because of the number of actuators and sensors are minimum (Merlet, 2006).

### 2. DELTA ROBOTS

A delta robot is a type of parallel robot which consists of arms connected to universal joints at the base. The basic idea behind the Delta parallel robot design is the use of parallelograms.

A parallelogram allows an output link to remain at a fixed orientation with respect to an input link. The use of three such parallelograms restrains completely the orientation of the mobile platform which remains only with three purely translational degrees of freedom. The input links of the three parallelograms are mounted on rotating levers via revolute joints. The revolute joints of the rotating levers are actuated in two different ways: with rotational (DC or AC servo) motors or with linear actuators. Finally, a mechanism is used to transmit rotary motion from the base to an end-effector

mounted on the mobile platform. The use of base-mounted actuators and low-mass links allow the mobile platform to achieve large accelerations up to 50 times the gravity (G) in experimental environments and 15 G in industrial applications. There are two kinds of Delta Robot: high-speed robot (objects that weight up to 1 kg) and robots to handle heavy objects. Both of them have a low inertia structures.

Delta robots are also famous for easy dismounting and mounting, for their low maintenance and for their flexibility, that is to say, changing the end-effector a Delta robot can carry out a wide range of actions (Bonev, 2000).

### 3. THE DESIGN OF DELTA ROBOT MECHANICAL SUBSYSTEM

At University of Zilina, Department of Automation and Production Systems is developed training Delta robot for education in areas of robotics and parallel kinematic structures.

Parallel kinematics of robot is based on a parallelogram mechanism is linked up with three rotating arms and the bottom platform, which we can freely move in linear axes X, Y and Z. Kinematics mechanism is in closed loop, which gives a simple mechanism for greater stability of structures and mechanical properties. The main task of this objective is to construct a realistic model of the Delta robot mechanism and its components, which will serve as an experiment and provide all necessary information.

The basic mechanism of Delta robots 3RRR consists of three closed kinematic loops, which are rotated in a closed kinematic chain around the robot axis of 120 degrees. A kinematic loop consists of a rotary arm, parallelogram and axial vector, which closes the loop.

The Delta robot kinematic scheme (Fig. 1) shows that the upper platform (green) is fixed in a Cartesian coordinate system with the centre (O; X, Y, Z), and the down platform (pink) is moving, on it is located effector. Arms angles are marked as  $\theta_1, \theta_2$  and  $\theta_3$  ( $\theta_1, \theta_2, \theta_3$ ), and TCP point ( $E_0; X_0, Y_0, Z_0$ ).

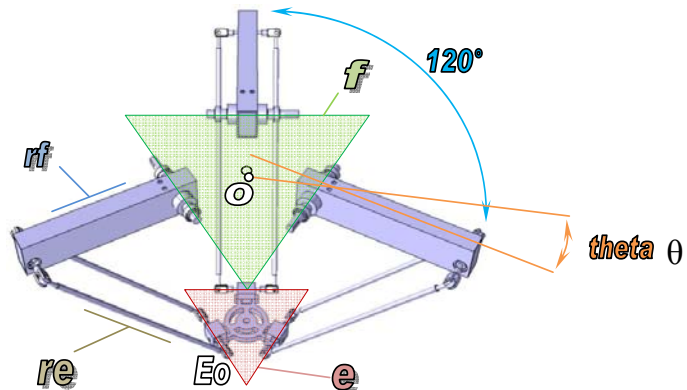

Figure 1. Scheme of key parameters of mechanism geometry:  $f$  - side of an isosceles triangle defined by axes of rotary arms,  $e$  - side of an isosceles triangle, defined by axes on down platform,  $rf$  - distance between two axis of the rotating arm,  $re$  - distance between two axis of rod,  $O$  - the reference point with the coordinate system

### 4. KINEMATIC ANALYSIS AND SIMULATION OF DELTA ROBOT CAERTEC RK 2010

Motion software and interpolation algorithms were designed mainly for the simulation module of Delta robot, interpolation algorithms for continuous control of end-member mechanisms with different numbers of degrees of freedom in space. Algorithms were designed for linear, circular and space interpolation.

Practical verification of the proposed mechanism and control system - at this point will be proven activity of control system in cooperation with the proposed simulation program and then tested the proposed control system of whole delta robot prototype.

Kinematic loops of Delta robot can be counted by forward kinematics, if we know the steering angles of arm  $\theta$  ( $\theta$ ) and we need calculate the relative position of the end point TCP, or by inverse

kinematics, if we know the coordinates of the end point TCP and we need to determine the position of the rotating arm.

In practice is mainly used the inverse kinematic analysis. For basic applications in the assembly or manipulation is suffice coordinates programming. More complicated industrial applications, such as machining or material cutting, already require interpolation of end point TCP - continuously control of the predetermined trajectory.

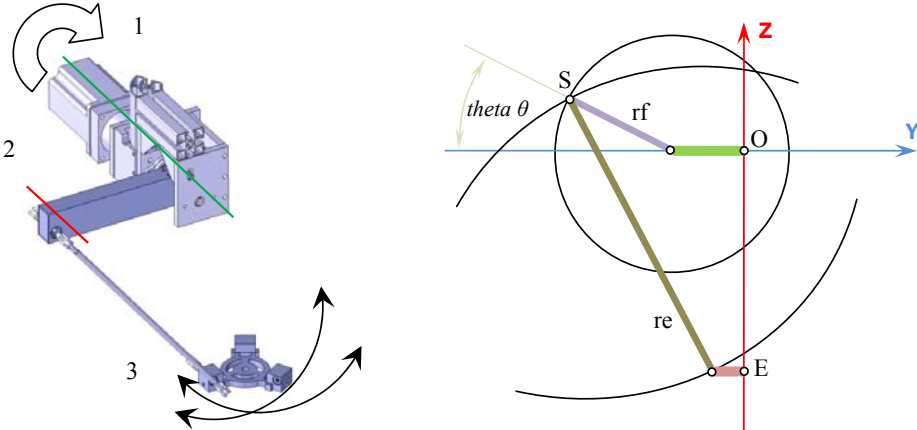

Figure 2. Kinematic chain of loop (left): 1 - axis of arm rotation, 2 – axis of parallelogram, 3 - tilting of parallelogram. General scheme of the plane ZY (right)

The main prerequisite for the delta robot design was the need to investigate and simulate the mechanism. The structural design and simulation has been developed using system CATIA, there were carried out static loading tests and calculations of the mechanism. The main output was design documentation that is necessary to construct the robot.

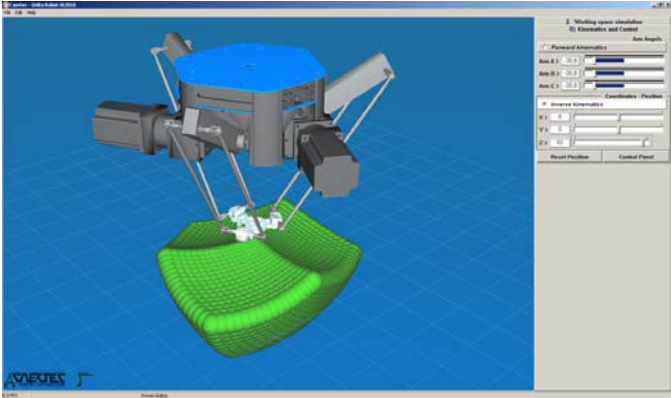

Figure 3. Analysis of robot workspace

For delta robot control and trajectory programming was developed software. The program allows the simulation and inverse kinematic analysis, workspace analysis, positions programming and communication management.

The geometric appearance of manipulation space is changing with different lengths of members of the robot kinematics. It consists of a set of intersections of three circles with centres at point S, which lies at the end of the rotating arms and occurs in all combinations of arms rotation.

A test version of the simulation and control program allows record a program that consists of points in the workspace robot. The program is then processed and sent to the controller - a microprocessor on board Arduino 2560th.

3D interpolation with a fixed rate is generated by sub-program in the microprocessor, which cooperates with the control electronics and actuators.

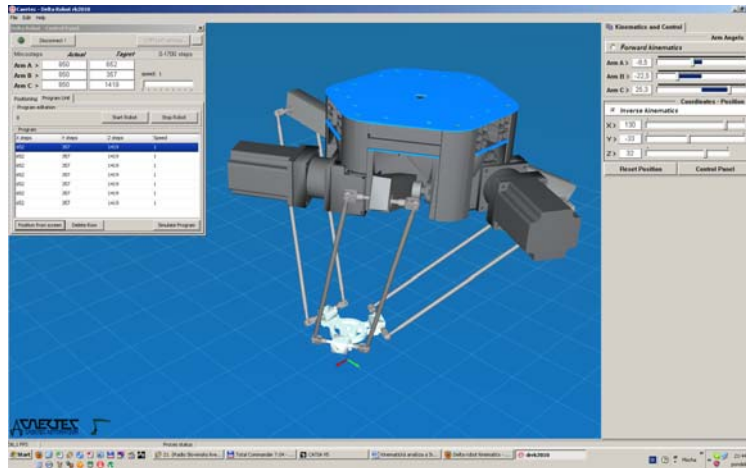

Figure 4. The mode of program creation

## 5. CONCLUSION

Parallel kinematic structures are interesting due to their high stiffness and high positioning accuracy compared to serial robots. This kind of mechanisms can be used in many fields but most of them are used as robots or as numerical controlled machine tools. Delta robot design has attracted great interest not only in industry but also in universities. This paper inform about development of mechanical subsystem, kinematic analysis and simulation of training Delta robot called CaerTec rk 2010 at University of Zilina. Parallel kinematics of robot is based on three parallelogram mechanisms. Kinematic loops of Delta robot were counted by the inverse kinematics. For delta robot control and trajectory programming was developed software that allows the simulation, the workspace analysis, the positions programming and the communication management.

## 6. ACKNOWLEDGEMENT

This article was created by the solution of project - code ITMS 26220220046: “The Development of Parallel Kinematic Structure Prototypes for Application in the Area of Machine Tools and Robots” supported by operational program Development and research, financed from European foundation for regional progress.

## 7. REFERENCES

- [1] Bonev I. 2003. Delta Parallel Robot — the Story of Success. <http://www.parallelic.org/Reviews/Review002.html>.
- [2] Zavatsky, M. 2009. Delta robot kinematics. <http://forums.trossenrobotics.com/tutorials/introduction-129/delta-robot-kinematics-3276/>.
- [3] Kolibal, Z. 2002. The theory of basic kinematic chain structures and its effect on their application in the design of industrial robot positioning mechanisms., ISBN 80-7204-196-7, Akademické nakladatelství CERM, Brno.
- [4] Merlet, J.-P. 2006. Parallel Robots. Dordrecht: Springer Academic Publisher, 2006, ISBN-10 1-4020-4133-0
- [5] Zhang, D. 2010. Parallel Robotic Machine Tools. Oshawa: Springer Science+Business Media, LLC 2010, ISBN 978-1-4419-1116-2, e-ISBN 978-1-4419-1117-9.
- [6] Adept. 2011. Adept Qattro Parallel Robots. <http://www.adept.com/products/robots/parallel>