

## OPTIMIZED MANUFACTURING SEQUENCE FOR HYBRID MANUFACTURING

**David Homar**  
Faculty of Mechanical  
Engineering  
University of Ljubljana  
Askerceva 6,  
1000 Ljubljana  
Slovenia  
david.homar@gmail.com

**Slavko Dolinšek**  
Institute for Innovation and  
Development of University  
of Ljubljana  
Kongresni trg 12  
1000 Ljubljana  
Slovenia  
slavko.dolinsek@iri.uni-lj.si

**Klas Boivie**  
Production Technology  
SINTEF Raufoss  
Manufacturing AS  
S. P. Andersens vei 5  
NO-7465 Trondheim  
Norway  
Klas.Boivie@sintef.no

### ABSTRACT

*The aim of the paper is to present computer software which analyse a geometric design of product and determine which part of product will be done with CNC milling and which part will be done with additive technology. Subsequently it split the CAD model of product on two or more part and save part for CNC milling in format which is used for making CNC code and save part for additive manufacturing in STL format. This means that we developed algorithm for automatic determining the most suitable manufacturing sequences and technologies and also for converting this algorithm in computer software. Algorithm is implemented in Solid-Works CAD software by C# programming language.*

**Keywords:** Hybrid Manufacturing, Milling, Selective Laser Melting, Computer Aid Design

### 1. INTRODUCTION

There are two or more processes at hybrid manufacturing. In our case it is about adding and removing materials. Every process of production has its advantages and disadvantages. The main goal of hybrid manufacturing is combining both processes and thus eliminating as much disadvantages as possible. The cutting process enables us to produce very accurate products with a high quality surface in a relatively short amount of time. Problems occur with products which have a complex geometrical structure. That is because the geometrical shape of the tool itself prevents us from producing a complexly structured product. The process of adding steel powder (our particular case is selective laser melting) is the exact opposite of the cutting process. The selective laser melting enables us to create any form because the product is created by adding materials in layers. Yet such a manufacturing consumes a lot of time and funds, furthermore it leaves us with product with a lower quality surface. Therefore our goal is to make most of the product with cutting as it is a much faster and cheaper process. The product of the cutting process would then serve as the base on which we would begin to add materials with the selective laser melting process. This is in order to produce the part which we could not be made by conventional cutting because of the geometrical structure of conventional tools. This paper presents a further research development of a hybrid manufacturing cell which is a combination of a powder bed additive manufacturing metal system and a 5 axis milling machine with the primary objective of producing injection moulding tooling inserts, however the principle should be applicable for a variety of different types of products [1].

## 2. ALGORITHM FOR THE AUTOMATIC SECTION OF THE CAD MODEL

Within the research project a hybrid cell whose purpose is the development of tool inserts for the injection of polymers with adjusted cooling channels is developed [2]. Such an insert is shown on *Figure 1*. The lower massive part of the insert will be produced with the cutting process as the cooling channels in this part are only straight. The upper part however has its cooling channels adjusted to the surface of the tool and therefore do not have a straight shape. This is not possible to machine with conventional milling, so this part shall be developed by the technology of adding steel powder [3,4].

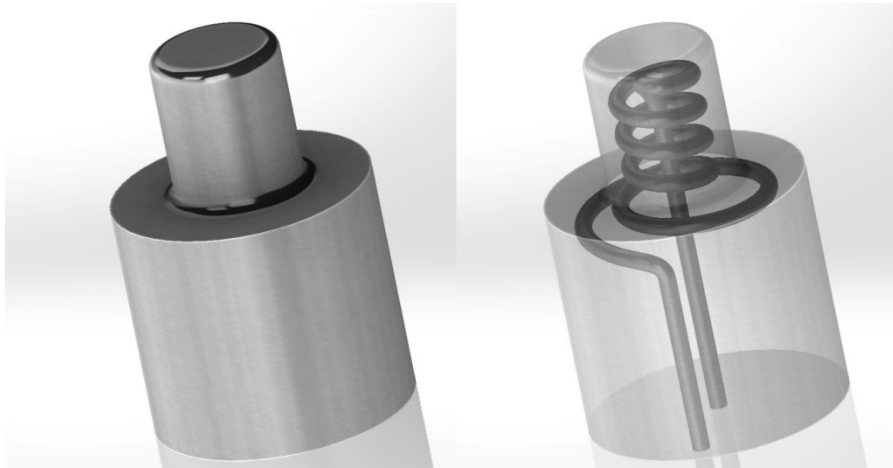

*Figure 1. Tool insert with conformal cooling channel*

The goal is to achieve a high level of automation. That is why we are also developing an algorithm for the section of the CAD model into two parts. We are aiming to insert the whole CAD model into the control system of the hybrid cell, after which the computer will recognize by itself to which altitude can it produce the model by means of cutting. Following this, the program would divide the analysed part into two and it would save the upper part in the STL format, which is the most wide spread format for layer manufacturing technologies. The lower part would be saved in the STEP or any other format which enables the generation of the CNC code for the milling machine. We have developed a new algorithm model for the automatic section of the CAD model. It works by first enveloping two points. The first one represents the minimal coordinates of the presented model and the second one represents the maximal coordinates. Further analysis shall be carried out in a rectangular space which is defined by these two points. Then we start to pierce the model with parallel vectors. The starting points of the vectors are beneath the basic plane. The vectors are perpendicular to the basic plane, as shown on *figure 2*.

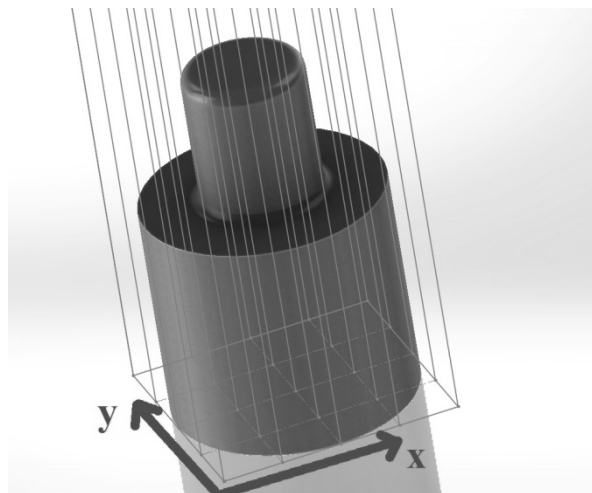

*Figure 2. Presentation of analysed model with vectors*

The key data for the analysis are the intersections of the vectors and the model (entrances and exits of vectors which are going in out of the model). Only vectors that have more than 3 intersections with the model shall be used. That is because the model also has an inner form at such spots. A minimal value of the Z coordinate of the first vectors exit with more than 3 intersections is a height to which the model can be made. On the basis, that a vector cannot reach the highest point of the model without intersecting, we can conclude that the cutting tool cannot reach the highest point without collision. That is why we can use the cutting process only to the aforementioned height. *Figure 3* presents a flowchart of the aforementioned algorithm.

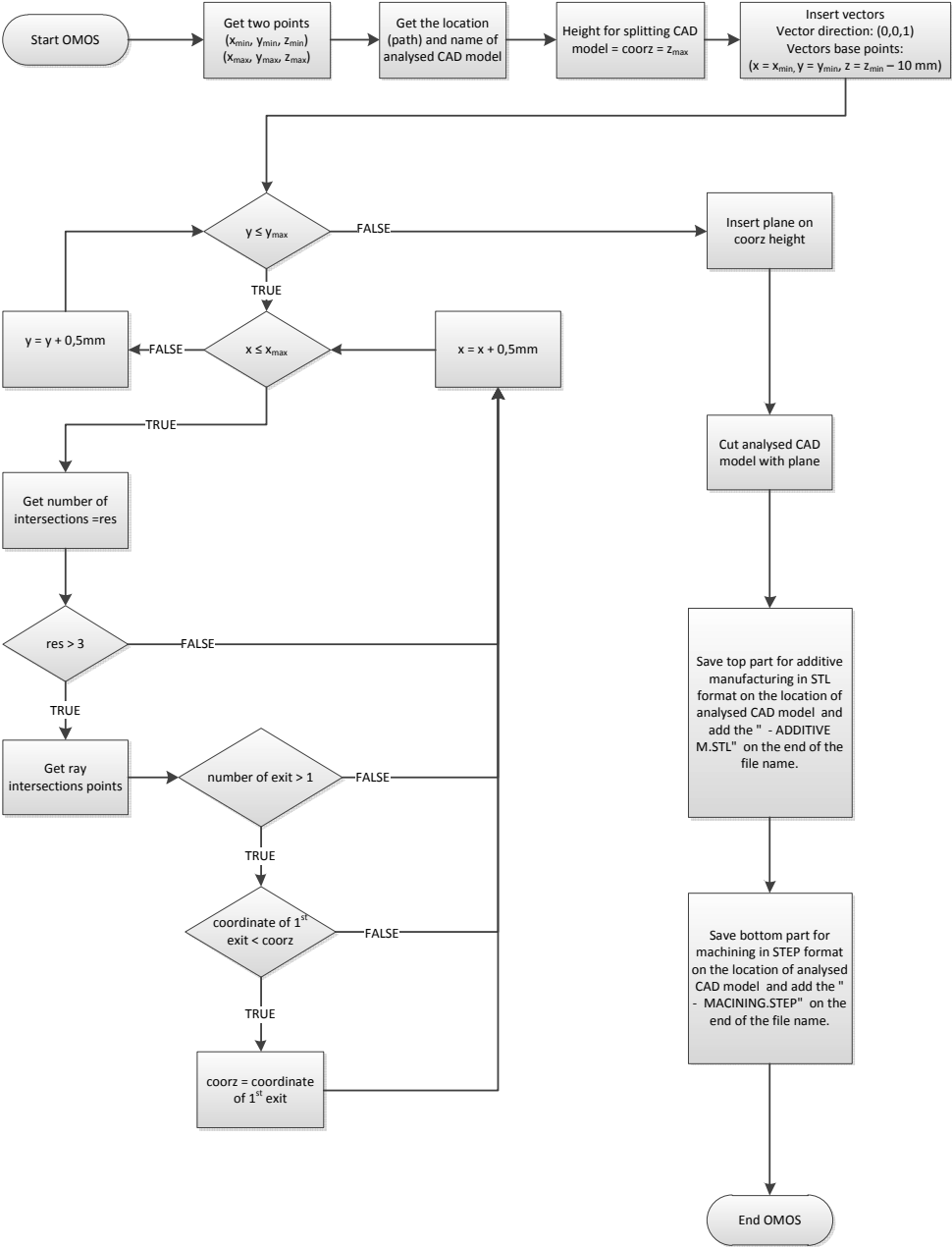

Figure 3. Flowchart of algorithm for CAD model analysis

The modeller’s algorithm defines the height to which it is possible to produce with conventional tools. After which the program on the defined height inserts a subsidiary plane which parallels the main lower plane of the developing tool. At last it divides the CAD model into two pieces. The programme saves the lower part in the STEP format in the folder which contains the former CAD model. The STEP format is meant for generating CNC code for milling. The upper part is saved in the STL format, for it is the most wide spread entry datum among technologies for adding materials.

The algorithm has been implemented into the Solid-Works modeller through the API interface which enables us to automatize function of the programs, those which already exist. Also, new functions with mathematical support and support other operations can be generated. API allow us to write programs in different languages, our algorithm has been implemented with using C#. The main added value is introduction of the vectors and how to search for the intersections with the model.

### **3. FURTHER WORK AND CONCLUSION**

The aforementioned algorithm needs to be further developed, for it enables a correct analysis only for models which have the beginnings of the cooling channels at the lower basic plane of the insert. In contrast, many of tools' inserts for injection-moulding of polymers have the cooling channel's beginnings at the side of the insert. Therefore it is appropriate that we apply the aforementioned analysis to more than just the lower side, as it is conducted now. We would then combine the results of different directions and acquire the correct height of the division of the CAD model.

When the algorithm and supported programme is fully developed, it shall be necessary to implement it to the control system of the producing cells. As such the control system will be able to foresee the appropriate process for the given height of the product. Also we will be able to determine all the zero points at the particular machine in relation to the movements of the products from one machine to the other together with the clipping system.

The hybrid production cell shall enable to produce one work-piece with two different processes. As such we will enable manufacturing of products in any form with minimal production expenses. It is quite visible, that technologists avoid accepting new technologies if they are not easy to use and/or if they produce more expenses. We expect that they will be more warmly open the aforementioned technology when most of operations will be automated. In conclusion, in such a way we would be more effective in introducing layer manufacturing technologies into the tool shops, as selective laser melting of steel powders.

### **4. REFERENCES**

- [1] Boivie K., Dolinšek S., Homar D.: Hybrid Manufacturing: Integration of Additive Technologies for Competitive Production of Complex Tools and Products, Proceedings of the International Research/Expert Conference: "Trends in the Development of Machinery and Associated Technology" TMT 2011, Prague, Czech Republic, 12-18 September 2011
- [2] Dolinšek, Slavko, Panjan, Peter, Syvanen, Tatu, Ramovš, Jože. Laser-sintered tools for the die-casting of aluminium. *Stroj. vestn.*, 2006, letn. 52, št. 11, str. 738-751.
- [3] K.P. Karunakaran, S. Suryakumar, Vishal Pushpa, Sreenathbabu Akula, Low cost integration of additive and subtractive processes for hybrid layered manufacturing, *Robotics and Computer-Integrated Manufacturing*, Volume 26, Issue 5, October 2010, Pages 490-499
- [4] Olivier Kerbrat, Pascal Mognol, Jean-Yves Hascoet, A new DFM approach to combine machining and additive manufacturing, *Computers in Industry*, In Press, Corrected Proof, Available online 6 May 2011