

APPLICATION OF MODELING AND SIMULATION IN REENGINEERING OF MANUFACTURING PROCESSES

Milan Jurkovic
Faculty of Technical Engineering, University of
Bihac, dr. I. Ljubijankić bb., 77000 Bihać, Bosnia
and Herzegovina

Zoran Jurkovic, Goran Cukor
Faculty of Engineering,
University of Rijeka, Vukovarska 58,
51000 Rijeka, Croatia

Miran Brezocnik
Faculty of Mechanical Engineering, University of
Maribor, Smetanova ulica 17, 2000 Maribor,
Slovenia

Milenko Sekulic
Faculty of Technical Sciences, University of Novi
Sad, Trg Dositeja Obradovića 6, 21000 Novi Sad,
Serbia

ABSTRACT

Mathematical modeling, optimization and simulation of processes have a great importance in the wide range of technical sciences and practice, as well as in all forms of quantitative researches, where efficacious using of theoretical knowledge into practical purpose. The application of mathematical modeling in manufacturing processes based on the application of knowledge, which is a prerequisite for the transformation of the conventional process in a modern, as need to be met optimality criteria's: technical, economical and market. Reengineering as the improving method of processes and systems are sets of the procedure of modeling and optimization of processes and systems at the first place. The paper discusses the modeling and the development of mathematical models, the application of modeling in the modernization and improvement of technological processes.

Keywords: modeling, simulation, optimization, reengineering, manufacturing

1. INTRODUCTION

Modeling and simulation of machining processes should achieve effective and efficient production, it means to improve existing processes and reduce production costs and shorten delivery time in order to achieve competitive advantage and ability.

Optimal selection of machining process directly affects on:

- minimizing processing time per unit of product,
- increase the productivity of processes and efficiency of manufacturing machining systems,
- increasing product quality and
- reducing the cost of preparing.

Therefore, manufacturing technologies and processes, which are applied over a certain conventional form may be innovate by appropriate modeling method with the help of high knowledge of modeling, simulation, optimization, process theory, computer technology and other areas [1-6]. Mathematical modeling and optimization methods are build up methods whose main goal is to innovate existing processes, modernization and higher techno-economic level processes (Figure 1).

2. REENGINEERING IN THE DEVELOPMENT OF MODERN PRODUCTION

Reengineering industrial production process of continuous innovation and improvement of existing products, technologies, production processes and systems whose effectiveness of application depends the survival of many manufacturing and business systems. The usefulness of reengineering can be

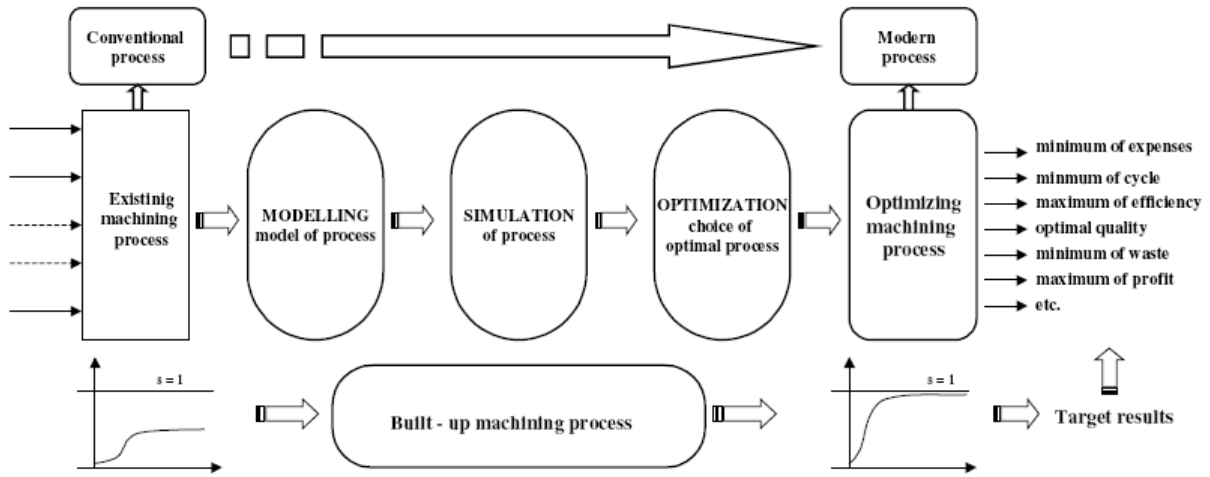

Figure 1. Classical and modern machining procedure [3]

observed in terms: the maximal simplification of working processes, reduce the amount of work, the improvement of business results, the implementation of new techniques and technologies, the advancement of product quality and market recognized manufacturing. Reengineering in the development of modern and profitable production system uses knowledge and innovation and reduces costs, ensures the quality of products that the market demands and place products on market at the Just-in-Time (Figure 2).

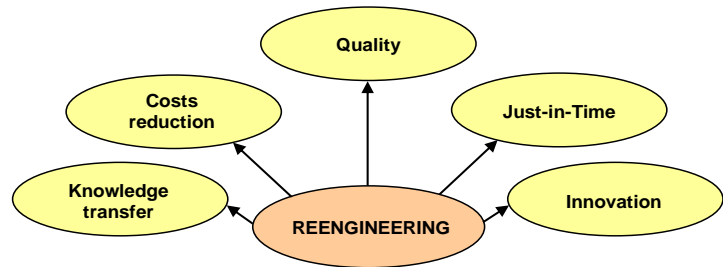

Figure 2. Reengineering in the development of modern production (key parameters of modern production) [1]

3. STOCHASTIC MODEL ALGORITHM: steps in model development

Methods of defining stochastic models can be based on a random processing of experimental data, when the conditions are not programmed (passive experiment) and the processing of data when the conditions of the experiment are programmed using the mathematical theory of the experiment design (active experiment) (Figure 3).

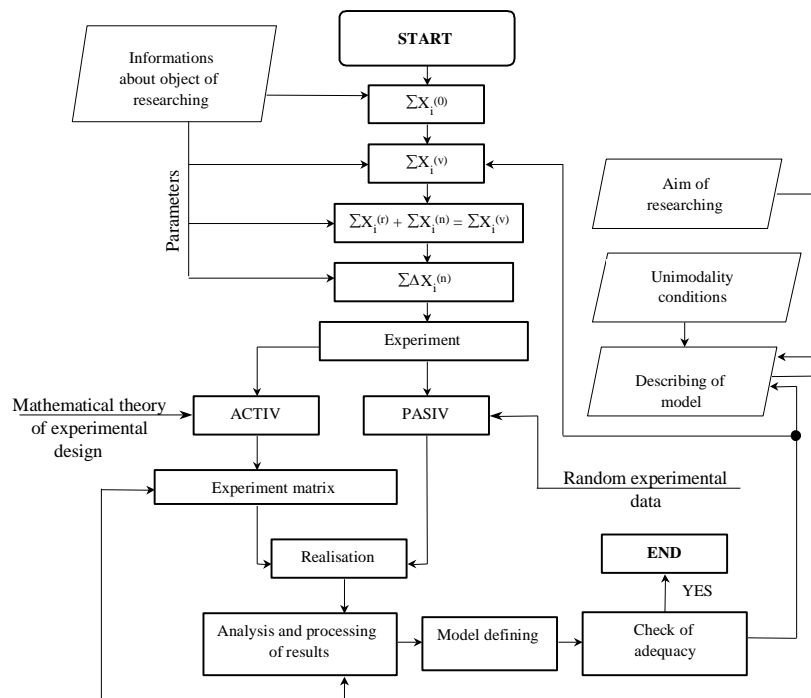

Figure 3. The general algorithm (scheme) of the development stochastic mathematical model

4. FORMING PROCESS IMPROVEMENT USING MODELING AND SIMULATION

4.1. Modeling and simulation of the profiles forming force from a strip

Thin-walled profiles can be plastic formed on the presses and the forming by means of rotary rolls (Figure 4). The manufacturing of thin-walled profiles from a strip by means of rotary tools is based on the gradual forming of strip by means of more forming modules with accurate profiled rolls [2-6]. Deformation force is needed to know in the designing of processes, the tool design and the choice of manufacturing system.

The mathematical model of force enables the knowledge of tool loading and computational simulation still in the phase of designing of profiles forming process. The force modeling has been performed for the three variables of process: profile angle α ($^{\circ}$), material thickness s (mm), and yield strength σ_f (N/mm^2). The constants of process are: manufacturing system, forming velocity, tool geometry and contact friction (Figure 5).

The material of profile is EN DC01 (1.0330) (Figure 6). The experimental obtained values of forming force at the profile forming according to Figure 6 are shown in Table 1.

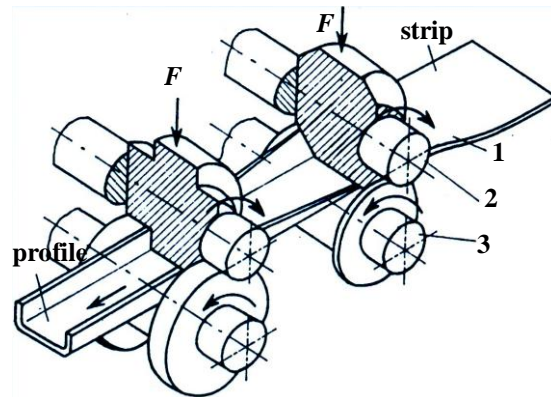

Figure 4. The profiles forming by means of rotary rolls 1. workpiece, 2. upper roll for profiling, 3. lower roll for profiling

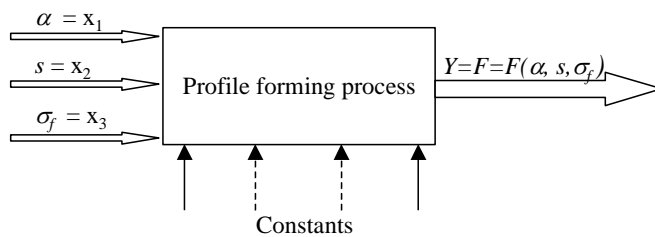

Figure 5. Scheme for forming force modeling (input-output parameters)

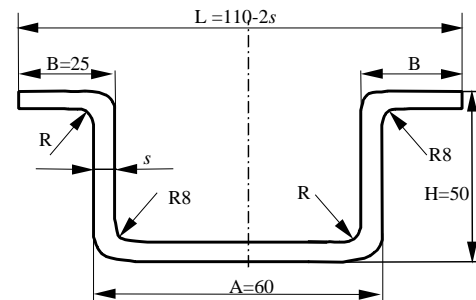

Figure 6. The cross-section of profile

Table 1. Review of experimental values of forming force

Number of trial		1	2	3	4	5	6	7	8	9	10	11	12
Physical variables of process	α ($^{\circ}$)	18	90	18	90	18	90	18	90	54	54	54	54
	s (mm)	1,5	1,5	3,0	3,0	1,5	1,5	3,0	3,0	2,25	2,25	2,25	2,25
	σ_f (N/mm^2)	240	240	240	240	360	360	360	360	300	300	300	300
Force F_f (daN)		181	743	284	1152	267	1115	426	1696	764	735	776	744

After the performed procedure of modeling a mathematical model of profile forming force in physical form has been obtained:

$$F = 46,0 - 1,153\alpha - 18,3s - 0,112\sigma + 0,685\alpha \cdot s + 0,149\sigma \cdot s + 0,0195\alpha \cdot \sigma + 0,009\alpha s \sigma \quad (1)$$

where the values of variables has been entered in expression (3) for: α ($^{\circ}$), s (mm), and σ (N/mm^2). The experimental verification of the mathematical model (1) is presented in Table 2. The simulation of obtained mathematical models (1) of the forming force of thin walled profiles is presented on Figure 7 and Figure 8.

Table 2. The experimental and calculated values of forming force (daN)

Number of trial		1	2	3	4	5	6	7	8	9	10	11	12
The values of forming force	Exp.	181	743	284	1152	267	1115	426	1696	764	735	776	744
	Cal.	188	750	291	1159	274	1122	433	1703	740	740	740	740

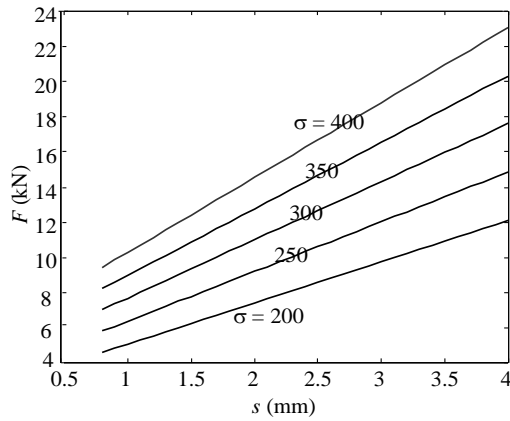

Figure 7. Simulation of model $F=f(\alpha, s, \sigma)$ for $\alpha=90^\circ$

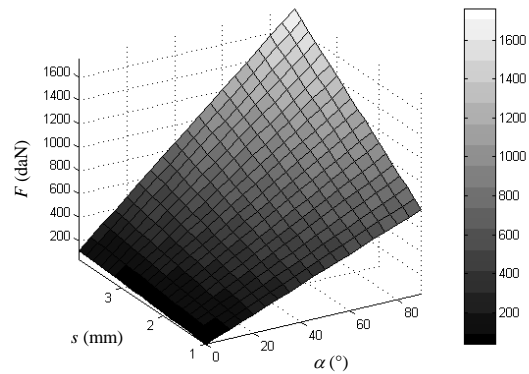

Figure 8. Simulation of model $F=f(\alpha, s, \sigma)$ for $\sigma=300 \text{ N/mm}^2$

5. CONCLUSION

Modern manufacturing engineering is sophisticated and is based on knowledge and innovation. Therefore it is not possible to solve the technological, design, cost and other problems of modern production without the use of advanced engineering and scientific methods, using the methodology and tools reengineering. Modeling and optimization methods give more opportunities to solve problems and improve manufacturing process. The needs for accurate description of the process are the greater with the development of modern and intelligent production systems and the application of computer techniques and information technology in which methods of modeling have special meaning. Force modeling cold forming profiles obtained by stochastic modeling, where the resulting mathematical model describes well the force shaping profile, or load tools. Results forces profiling obtained experimental measurements and modeling are acceptable and reliable, and adequately describes the process of the profile forming.

6. ACKNOWLEDGEMENT

This paper was supported by the *Federal Ministry of Education and Science of Bosnia and Herzegovina, no. 01-2440/13* and the *University of Rijeka, Croatia, no. 13.09.1.2.10*.

7. REFERENCES

- [1] Jurković M., Jurković Z., Buljan S., Mahmić M.: Reengineering of production enterprise - Development and Modernization of Production (in Croatian), University of Bihać, Bihać, 2011. pp. 1-560. ISBN 978-9958-9269-7-6
- [2] Jurković, M., Mathematical Modelling and Optimization of Machining Processes, Faculty of Engineering, University of Rijeka, 1999.
- [3] Jurković M., Jurković Z., Karabegović E., Dan-Sorin Comsa: The Choice of the Optimal Machining Procedure by Modeling and Simulation Application, RIM-2003, University of Bihać, 2003.
- [4] Jurković Z., Jurković M.: Modelling and optimization of the tool geometry for deep drawing of sheet metal, Metallurgy 39 (2000)4, 231-236. ISSN 0543-5846.
- [5] Jurković M., Jurković Z., Buljan, S.: Mathematical Modelling in Machining Processes Application, Proc. 10th Int. Scientific Conf. 2002, Slovak University of Technology in Bratislava, Trnava, 2002.
- [6] Jurković M., Jurković D.: Modelling and Optimization Methods in Machining Processes Application, Proc. 1st Int. Conference ATDC-2002, 199-206, Faculty of Engineering, Slavonski Brod, 2002.