

## VERIFICATION OF PREDICTED THERMO-CYCLES DURING LINEAR FRICTION WELDING

Univ. Assist. Mr Petar Tasić, Dipl.ing.  
Faculty of Mechanical Eng. Sarajevo  
Vilsonovo šetalište 9, Sarajevo  
Bosnia and Herzegovina

Doc. Dr. Damir Hodžić, Dipl.ing.  
Faculty of Mechanical Eng. Sarajevo  
Vilsonovo šetalište 9, Sarajevo  
Bosnia and Herzegovina

Doc. Dr. Ismar Hajro, Dipl.ing.  
Faculty of Mechanical Eng. Sarajevo  
Vilsonovo šetalište 9, Sarajevo  
Bosnia and Herzegovina

### ABSTRACT

*In linear friction welding notable is presence of intense material flow, caused by forces required for heating and forging. These forces also can be used as moderator of welding process, if properly controlled and if welding system is rigid enough. Welding process is very short, often under 5 seconds, during which material undergoes rapid heating and cooling. This is specially issue with steels, where intensive plastic deformation causes changes in transformation during cooling. A lot about structure can be understood through accurate prediction of thermo-cycles. However, that has its own challenges. This paper presents possibilities for verification of thermo-cycles predicted by numerical simulation, so the steel microstructure can be accurately predicted, as well as properties. Main problems are elaborated, along with suggestions for verification improvement, leading to better understanding of such complex process.*

**Keywords:** linear friction welding, temperature, cycle, prediction, verification

### 1. INTRODUCTION

Among all welding processes, especially interesting are those where significant heat is produced by friction, and yet there is no melting of material. Therefore, they are named solid state welding processes. Friction group includes rotational, linear and friction stir welding processes, as well as their variations. Peak temperature in all friction welding processes usually is approximately 80% of melting temperature [1]. This fact enables avoidance of all negative issues due to material solidification, and, in overall, improves quality of final product.

There are several important process parameters in linear friction welding, and among the most important ones are frequency, amplitude, friction and forging force. It is believed it could be possible to control quality of welds only by controlling shape of flash produced during welding [2]. This means that flash shape could be used as indication of weld quality. Since shape of flash is easy to control (by camera or such device) and easy to change in production (by simply adjusting welding parameters), this could significantly change the way quality check is done. Therefore, by adjusting e.g. frequency, "preheating" could be done and cooling rate decreased, avoiding martensite in weld. This could be especially useful for welding of large cross-sections, where linear friction welding process is able to provide uniform heat generation. As a result, it would be possible to examine welds simply by checking their look and appearance.

However, to establish such *on-line* quality control through process control, some research had to be done. It is required to establish relationship between welding parameters and weld shape. To achieve this, it is necessary to take one parameter, which is easy to trace, and use it to develop this relationship. Temperature during welding could be used for this purpose.

## 2. PREDICTION

Temperatures and thermo cycles during (linear) friction welding are commonly predicted based on literature sources. However, most of data available for any kind of friction welding is related to Ti an Al alloys [3,4], while those related to linear friction welding of steel are relatively scarce [5]. It should be bear in mind that for welding of steel rotational friction welding is by far more popular over linear friction welding, even though it has limited usability. Linear friction welding is still not widely used for steel (especially large cross-sections) due to high energy consumption and low energy efficiency. Nevertheless, it is possible to analyse hardness of welded steel samples (Figure 1), and combine obtained data with CCT diagrams (if available) of corresponding steel to estimate at least cooling rate.

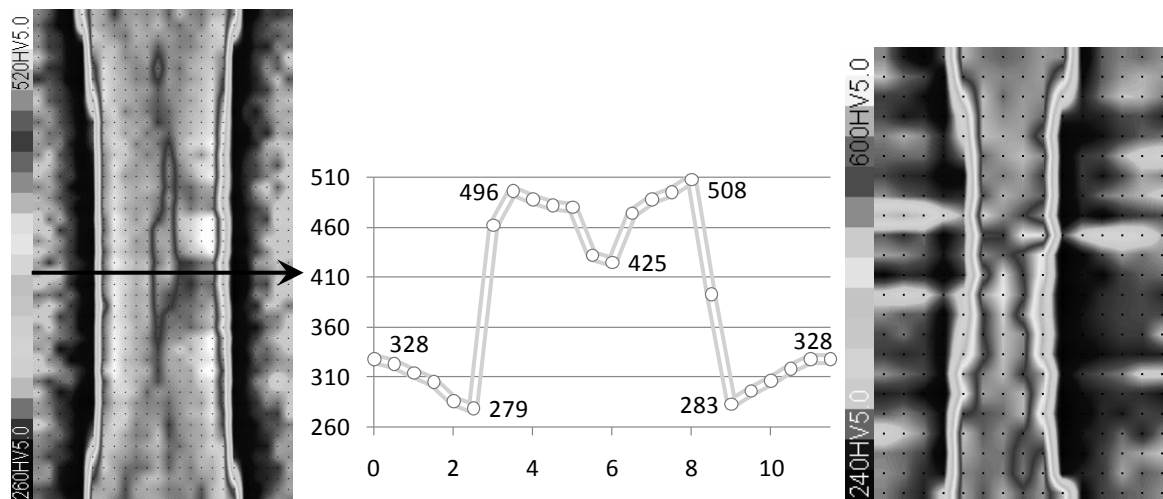

Figure 1. Hardness obtained over cross section (left is  $\phi 26$ , middle is hardness in denoted section, right is  $\phi 12$ )

As possible to see in Figure 1, there is significant difference between cross sections of diameter 26 and 12 mm, not only in peak hardness, but in hardness distribution as well. Note that both specimens are welded with exactly the same parameters. Specimen of 12 mm shows expected significant increase in hardness in weld zone (metallography confirmed high martensite content), and steep decrease in heat affected zone. However, specimen of 26 mm shows significant drop of hardness in the middle of entire cross section, possibly due to annealing (it has considerably larger cross-section). It is important to mention material flow, which is highly influential factor on temperature cycles in certain points. Back to this softened zone, this could mean that colder base metal has been pushed into middle during forging phase, where it undergoes annealing.

Based on this, it is easy to conclude that estimation of cooling rate, as a very important factor for prediction of overall weld properties, is quite challenging task in case only hardness is available, while it is almost impossible to describe entire thermo cycle using hardness.

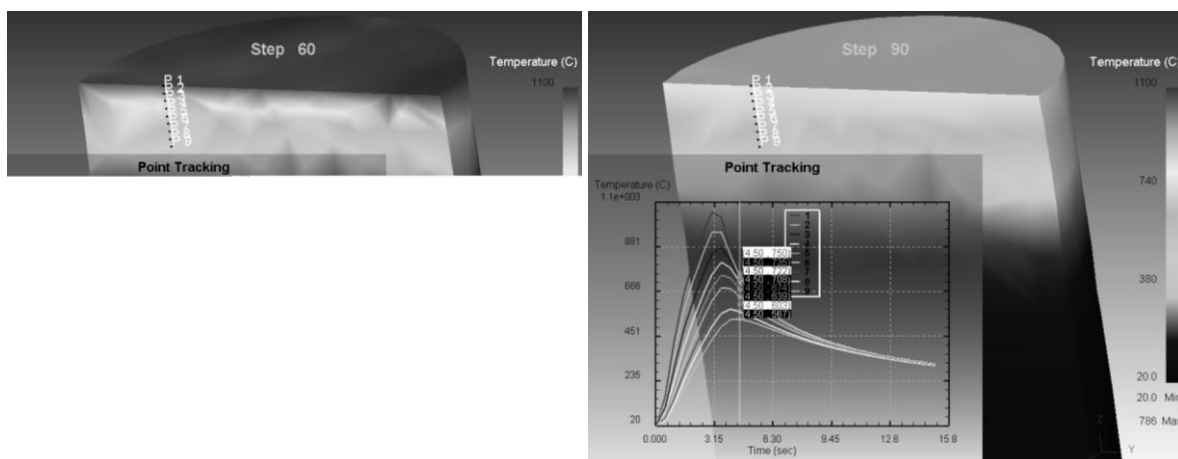

Figure 2. Prediction of thermo-cycle in Deform (max. temp is 1050°C)

Certainly, there was possibility to predict thermo-cycle by using simulation (Figure 2). For that purpose, commercially available FEM software Deform was used. However, any simulation of this kind requires experimental verification, and therefore it has been crucial to measure temperatures achieved in material during welding.

### 3. EXPERIMENTS

By welding steel specimens (0,25% C, 1,3% Mn) at SLV Munich, a lot of data regarding welding process and welds has been collected. Although it is possible to say that most of welds made with exactly the same parameters look almost exactly the same, it is still necessary to establish relationship between process parameters and outcome, represented as shape of flash. One of the best indicators of process, from the beginning to the end, is temperature. By knowing the temperatures during welding cycle, it is possible to maintain and predict microstructure and, consequently, properties of material and weld.

Linear friction welding is specific, since material undergoes significant flow during both welding and, even more, forging phase. Since material is flowing, temperature fields are moving as well. This problem is more expressed in case of large cross-sections, where significant amount of heated material is pushed out (forming flash), and replaced with colder base material.

This means that “usual” ways of temperature measurement are not appropriate. In this case, data obtained on the surface, either by using pyrometer or thermocouples, reveals no data on temperature fields and cycles inside the material, and, consequently, on material flow.

Because of this, specific welding specimens have been made (Figure 3), consisting of two halves. One has small slots for thermo-couples, while the other half covers the first and makes round specimen. Halves were bonded by two component adhesive, and used after seven days of drying.

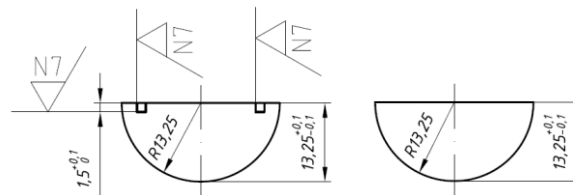

Figure 3. Cross-section of specimens for temperature measurement (half with slots is shown left)

Each specimen has been able to accommodate two thermo-couples in two different positions. Thermo-couples were positioned at 12 various distances from top of the specimen, varying from 0,8 to 7 mm (Figure 4). This has been done with purpose, even though was known that some of them will be destroyed within first few moments of welding. The only goal has been to acquire as much temperature data as possible.

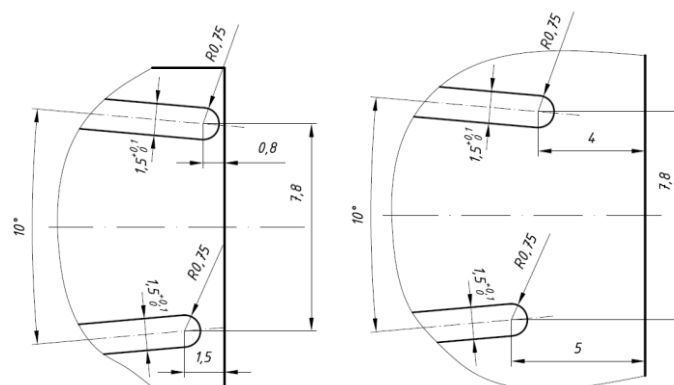

Figure 4. Examples of positions of slots for thermo-couples in specimen

Thermo-couples were fixed in positions and insulated with ceramic. After bonding and drying, specimens were used instead of normal (usually used) ones, and temperatures were recorded. It was expected that results from number of thermo-couples will not be useful due to strong vibrations, loss of contact, and intensive material flow. Maximal temperature expected at points where measuring has been done was 1000°C.

#### 4. RESULTS AND DISCUSSION

Figure 5 shows results of temperature measurement in four points shown in Figure 4. Peak temperature coincides with beginning of forging phase (i.e. end of friction phase). As it is possible to see, peak temperatures are over 1000°C, even in points 5 mm from contact surface. Also, it is possible to notice presence of temperature variation in points 4,0 and 5,0 mm from contact. This can be easily explained by material flow, where relatively cold base material is pushed closer to contact and undergoes rapid heating due to both conduction and mixing.

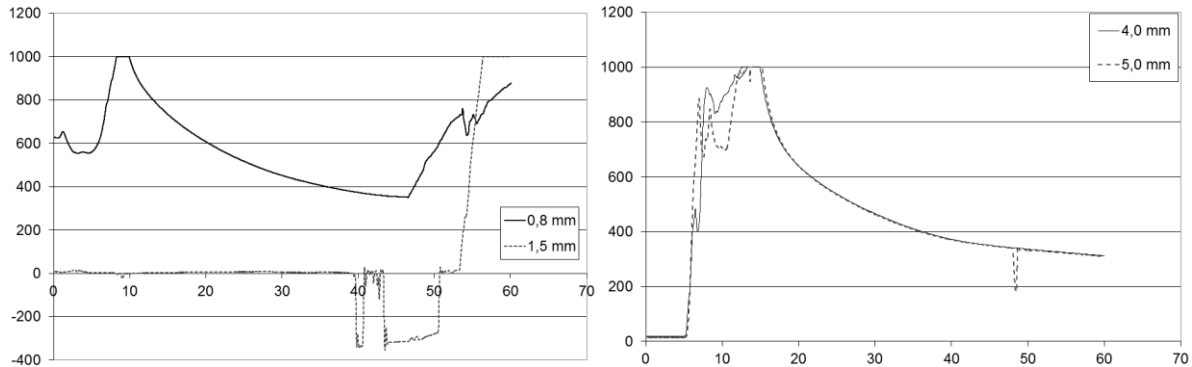

Figure 5. Temperatures measured during welding at different distances from contact surface

The rest of measurements (not present here due to amount of diagrams and data), shown significant problems with temperature measurement. Problems are very similar to those observed with point 1,5 mm from contact (scattering, instability and saturation of signal).

It is necessary to consider existence of higher peak temperatures, basically in any point within 15 mm from contact surface (for this cross-section), and to fix thermo-couples in a way they can give reliable and stable signal. Only then will be possible to use temperature measurements as verification for predicted thermo cycles, and establish chosen method of prediction as a reliable one.

#### 5. REFERENCES

- [1] Wanjara P., Jahazi M.: Linear Friction Welding of Ti-6Al-4V: Processing, Microstructure, and Mechanical-Property Inter Relationships, Metallurgical and materials transactions A, Vol. 36A, pp. 2149-2155, 2005
- [2] Bhamji I. et al: Linear friction welding of aluminium to copper, Science and technology of welding and joining, Vol. 17, No. 4, 2012, pp. 314-320
- [3] Vukčević M. et al: Measurement in friction stir welding process, Proceedings of 15<sup>th</sup> TMT Conference, Prague, Czech Republic, 12-18 September, 2011
- [4] Wen G. D. et al: Mathematical modelling of joint temperature during linear friction welding of dissimilar Ti-6.5Al-3.5Mo-1.5Zr-0.3Si and Ti-5Al-2Sn-2Zr-4Mo-4Cr alloys, Journal of Engineering Science and Technology Review, Vol. 5, Issue 3, 2012, pp. 35-38
- [5] Khany S. E., Krishnan K. N., Wahed M. A.: Study of Transient Temperature Distribution in a Friction Welding Process and its effects on its Joints, Intl. J. of Comp. Eng. Research, Vol. 2, Issue 5, 2012, ISSN 2250-3005 (online), pp. 1645-1665