

## RESEARCH TOUGHNESS OF WELDS BY THE PROCESS OF FRICTION STIR WELDING

**Ph.D. Nikola Šibalić**  
University of Montenegro  
Faculty of Mechanical Engineering  
Džordža Vašingtona bb, 81000 Podgorica  
Montenegro

**Ph.D. Milan Vukčević**  
University of Montenegro  
Faculty of Mechanical Engineering  
Džordža Vašingtona bb, 81000 Podgorica  
Montenegro

**Ph.D. Sreten Savićević**  
University of Montenegro  
Faculty of Mechanical Engineering  
Džordža Vašingtona bb, 81000 Podgorica  
Montenegro

### ABSTRACT

The paper was carried out welding sheet metal thickness of 5 mm, using a method of FSW (Friction Stir Welding). The process FSW has extensive application in modern industry. Ecologically clean, ie does not pollute the environment and safe for workers. This paper research the impact toughness which has a large influence on the quality of welded joints.

**Keywords:** FSW, impact toughness, shoulder, pin, welding speed

### 1. INTRODUCTION

During the nineties of the last century a new method for joining of similar and dissimilar material is performed in the solid state without melting the material known under the name of "Friction Stir Welding" - FSW. The method is patented by "The Welding Institute" - TWI in the UK in December, 1991, and found it was Wayne M. Thomas who has successfully joining aluminum alloys [1, 2, 3, 4]. The method is very quickly found its application in modern industry and caused a lot of scientific interest. The first application of the process was to merge material exclusively from aluminum alloy. This was followed by the welding of other materials such as: copper, magnesium, steel, titanium, etc. and also welding dissimilar materials, where the largest industrial application has welding steel and aluminum [3]. FSW process, is performed on the machine for welding (universal milling machine or CNC machine), using specially designed tools. Tools that are used in the process of welding are cylindrical and consisted of two concentric parts (Figure 1.a), which are rotating at the great speed. A larger diameter part of the tool is called the shoulder, while the smaller diameter part is called the pin. Rotating tool slowly approaches the joint line and plunges into material, which creates heat.

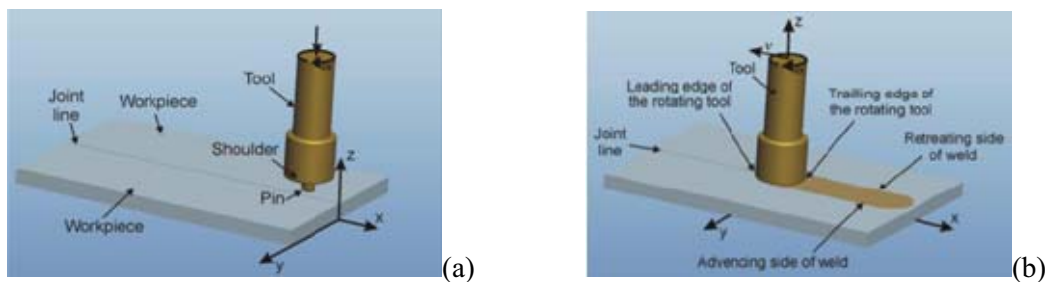

Figure 1. Tool and workpiece.

Due to that the temperature increases to the heat metal forming where mechanical mixing and joining of materials is performed, enabling the tool to move in the longitudinal direction or along the joint lines (Figure 1.b). After passing of the tool along the joint lines the solid phase of weld (joint) remains, where the upper plane remains smooth and flat thanks to the tool shoulder, while the lower plane of the work piece is formed from the basis on which the work piece is standing and it is also smooth and flat [1, 2, 3, 4].

## 2. EXPERIMENTAL RESEARCH

The material used in experimental research is sheet aluminum alloy according to European standard EN-573-3 numerical mark 6082-T6 or alphanumeric AlSi1MgMn. This alloy has a great industrial application. In the paper, the quality control of materials is done and determined the chemical composition using quantometer. The analysis was performed on two samples (Figure 2), and the chemical composition is given in Table 1.



Figure 2. Chemical analysis of samples.

Table 1. Chemical composition of aluminum alloy plate 6082-T6.

Sample	% Al	% Fe	% Si	% TI	% Cu	% Zn	% V	% Cr	% Mn	% Mg	% Na
1	98.25	0.22	0.85	0.01	0.002	0.062	0.006	0.001	0.16	0.43	0.002
2	98.29	0.21	0.83	0.01	0.002	0.060	0.006	0.001	0.15	0.43	0.001

Workpieces of dimensions 2000 mm x 50 mm, are obtained by cutting the plate with the thickness of 5 mm. Macrostructure of the alloy 6082-T6 is shown in Figure 3. The mechanical properties of the base materials of the workpiece are shown in Table 2, and physical properties in Table 3.



Figure 3. Macrostructure of alloy 6082-T6, thickness of 5 mm.

Table 2. Mechanical properties of the used alloy 6082-T6 (AlSi1MgMn).

Yield Strength 0.2 %	Tensile Strength	Rupture Strength	Elongation A5	Hardness Vickers
310 MPa	340 MPa	210 MPa	11 %	100 HV

Table 3. Physical properties of the used alloy 6082-T6 (AlSi1MgMn).

Density	Melting Point	Young's modulus	Electrical Resistivity	Thermal Conductivity	Thermal Expansion
2.70 g/cm <sup>3</sup>	555 °C	70 GPa	0.038x10 <sup>-6</sup> Ω.m	180 W/m.K	24x10 <sup>-6</sup> / K

For experimental research vertical milling machine was used, friction stir welding is performed in laboratory conditions, which are similar to the production conditions. Material of welding tool was 1.2343 steel according to the standard EN 10027-2. The tool was designed in CREO, using a program for parametric modelling (Figure 4.a). For welding of sheet of aluminium alloy the family of tools is adopted where the geometrical parameters are varied. The tool is axisymmetrical and consisted of the workpiece and body of the tool. The body of the tool is adjusted to the jaws of the machines used in the experiment. The general appearance of the family of tools for FSW process is given in Figure 4.b. Based on preliminary researches, the multifactor orthogonal plan with varying of factors on two levels, and repetition in the central point of plan  $n_0=4$  times is adopted. For input values, factors of the welding regime are adopted:  $X_1=v$  mm/min (welding speed),  $X_2=\omega$  rpm (rotation speed of tool) and geometrical factors of tools:  $X_3=\alpha^\circ$  (angle of pin slope),  $X_4=d$  mm (diameter of the pin) and  $X_5=D$  mm

(diameter of the shoulder). Levels of variation of input factors are adopted and given in Table 4. Presentation of tools in a central point of the plan is given in Figure 4.c.

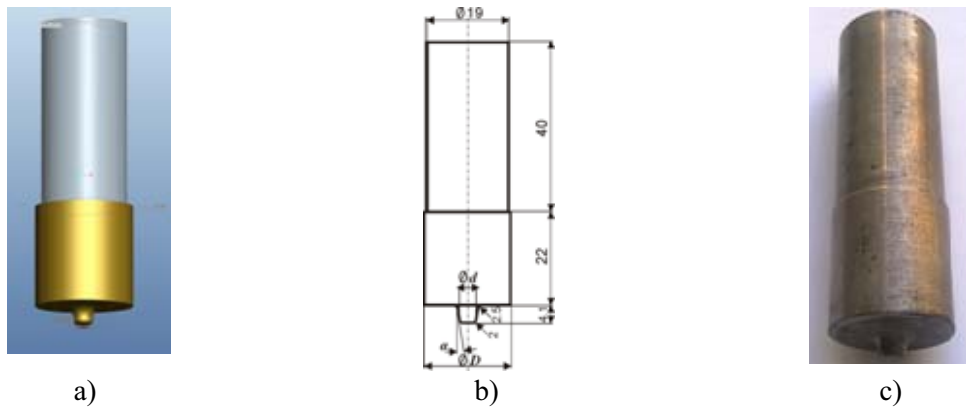

Figure 4. Friction stir welding tools.

Table 4. Levels of variation of input factors.

Input factors	Lower level:	Basic level:	Upper level:
$X_1$	125	200	315
$X_2$	800	1000	1200
$X_3$	4.5	4.97	5.5
$X_4$	4	4.9	6
$X_5$	18	19.9	22

Figure 5. shows the complete process of friction stir welding with basic tools and materials with supporting equipment. The testing is performed with the standard testing machines and test pieces. Impact toughness testing of the welded materials is done by impact loading to Charpy pendulum (Figure 6), with a maximum initial available energy 150 J.



Figure 5. Machine performing FSW.



Figure 6. Charpy pendulum.

Samples which are cropped from welded workpieces were taken from  $y$  - directions (normal to the direction of welding - side direction). Figure 7. provides a schematic view of test pieces. Test specimen particular shape and dimension fractures with one impact. On impact specimen is exposed to bending. The samples was made on the basis of the standard EN 10045-1: 1993, and the samples were cut in the direction normal to the direction of welding, as shown in Figure 7. Adopted a narrow pattern with a V-notch.

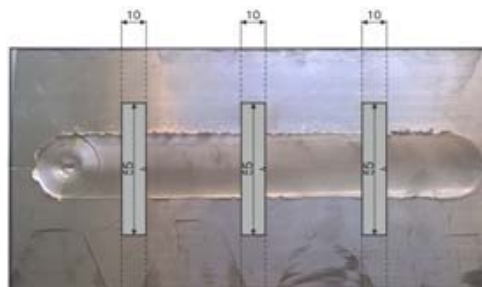

Figure 7. Welded joint with the presentation of the cropped samples.

The aim of the test is to determine the impact toughness of materials welded FSW process. The toughness of the welded material or strength of the impact in bending is the work spent to fracture the test specimen reduced to a unit cross section of sample:

$$\rho = \frac{N}{A} \text{ J/cm}^2. \quad \dots (1)$$

Figure 8. provides the samples of the test piece in the central point of the plan in  $y$  - direction. Figure 9. provides an overview of the tested sample in the central point of the experimental plan number 36. The study was carried out at room temperature.



Figure 8. The specimen for testing impact toughness.

Figure 9. The tested sample.

When performing mechanical tests, and determination of the impact toughness of samples in Charpy pendulum is done. Then, using regression analysis to model the values the impact toughness with a quadratic function response is obtained. Figure 10. shows a graph which compare the experimentally obtained values with a model obtained values.

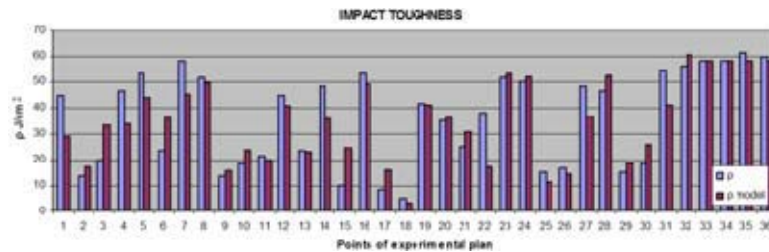

Figure 10. Chart comparisons experimentally and a model values.

### 3. CONCLUSION

The experimental research successfully completed the joining of aluminum alloy 6082-T6 using friction stir welding procedure (FSW). Experimental research has established that the dimensions of tools (shoulder diameter, pin diameter and angle of pin slope) have large effect on the quality of weld as well as regimes of welding (welding speed and rotation speed). The paper presents FSW process and mechanical tests were performed - determination of the impact toughness of welded joints. From Figure 10. we observe some deviations in some points of the experimental plan (1, 3, 4, 5, 6, 7, 14, 15, 22, 27 and 31). The central point of the experimental plan discrepancies are minimal. These deviations are due to the existence of a "tunnel" effect. Points of experimental plan, in which the "tunnel" effect is present to get small values impact toughness due to less cross-sectional area, which is weakened by hollow "tunnel" effect. The minimum values of impact toughness occurring in the 17<sup>th</sup> and 18<sup>th</sup> point of the experimental plan and the amount  $\rho_{17}=8.25 \text{ J/cm}^2$  and  $\rho_{18}=4.83 \text{ J/cm}^2$ . The maximum value of impact toughness is obtained for the center point of the experimental plan number 35 and is  $\rho_{35}=61.66 \text{ J/cm}^2$ . Based on the experimental results of FSW welding joints of aluminum alloy 6082-T6, it can be concluded that this procedure with the use of optimal parameters of welding, welded joints with good characteristics can be obtained.

### 4. REFERENCES

- [1] Thomas M. W.: et al 1991 Friction Stir Butt Welding international Patent Application No PCT/GB92/02203.
- [2] Dawes C., Thomas W.: Friction Stir Joining of Aluminium Alloys, TWI Bulltin 6, 1995., pp. 124-127.,
- [3] Vukčević M, Plančak M, Janjić M, Šibalić N.: Research and analysis of friction stir welding parameters on aluminium alloys (6082-T6), Journal for Technology of Plasticity, 34-1-2, 2009., 49-57.,
- [4] Mishra R., Mahoney M.: Introduction, Friction Stir Welding and Processing. ASM International 2007. 1-5.

**Acknowledgements:** The research presented in this paper are realized within the project RTPPIMS&NS, No. 01-376, Ministry of Science of Montenegro.