

AUTOMATED SYSTEM FOR SURFACE PROTECTION

Emina Begović
University of Zenica
Fakultetska 3, Zenica
Bosnia and Hercegovina

Darko Petković
University of Zenica
Fakultetska 3, Zenica
Bosnia and Hercegovina

Malik Čabaravdić
University of Zenica
Fakultetska3, Zenica
Bosnia and Hercegovina

Edin Garić
Company BME
Kraševo b.b., Tešanj
Bosnia and Hercegovina

ABSTRACT

In this paper, an analysis of the production process in a company which deals with the production of different steel structures has been conducted. Considering the fact that in the company, serial and individual production run through factory process simultaneously and in parallel, it is not realistic to think about implementing complete production automation. After completing the analysis, it has been concluded that a partial automation for surface protection can be implemented. The current way of carrying out surface protection in the mentioned company has been described, and also some suggestions for improving the automated line for surface protection have been given. These suggestions imply the induction of a means of transport and crane powered by an electric motor and also, implementation of automatic regulation.

By using the PLC system, specifically special purpose module, programming in a ladder diagram has been conducted, which in this case, is used for engine manipulation during horizontal movement of the vehicle in the line for surface protection.

Keywords: automatization, surface protection, PLC system

1. INTRODUCTION

Production automatization implies the transmission of work from man to engines, machines and plants, usually for technological improvement. Automation represents a continuation of a mechanization. Automation includes all measures and processes that reduce the proportion of human labor, perception and decision-making.

In order to implement automatization, it is necessary to carry out an entire range of economic, technological and organizational conditions. Also, an important aspect of conducting automatization of processes (engines, machines and plants) is the price of the system. That is why during the

designing of the system, a process analysis is made in order to determine the parts of the process that are reasonable to automate.

Characteristics associated with automated systems are reliability, repeatability, accuracy, independence of human effort and commitment and reduced production costs. Product automatization follows the technological development in production and models the implementation of management and other processes without direct human action.

The technologies of industrial processes today are using increasingly programmable logic controllers. Programmable logic controller is a computer, designed for application in an industrial environment, which can be programmed to perform control functions. An important feature of a ladder diagram is that industrial engineers do not have to be experts in programming in order to use PLC controllers in their systems.

BME d.o.o. is specialized in the production of steel structures. The company has a separate engineering department, a components department, a welding department and a department for surface treatment. BME's strength is the production of components and steel structures according to customers' specifications. The process of BME is designed on the principles of a modern production technology, where serial and individual production flows are simultaneously planned through the factory.[1]

2. CURRENT SURFACE PROTECTION LINE

The process of surface protection in the company BME is done in three cabins. As shown in figure 1, the first cabin is used for sand blasting, the second cabin for basic painting and the third cabin for final painting.



Figure 1. Department for surface protection in the company BME

Transportation between and within the cabins is done using rail vehicles, carts. Transportation is carried out by workers dragging the cargo on a rail trolley. Considering the type, size and weight of cargo handled, the distance to which the cargo is transferred and the quality of the transportation line, it would be good to find a solution that excludes human labor.

The solution that excludes human labor include following:

- The introduction of the means of transport by an electric motor to avoid the participation of human labor during the transport of products from one cabin to another.
- Cargo handling could have been much easier if the vehicle is located on vehicle. This would avoid the usage of bridge cranes and therefore the need for a large number of trailer rotations in the process of sandblasting, metallization and painting. By using mechanical or hydraulic lifts, it could be able to adjust a lifting height and thus the worker could have an easier access to the trailer during the process of sandblasting or painting.
- Using the PLC system to manage certain functions and processes, such as position control and visual control, would greatly facilitate and speed up the production process itself.

3. SUGGESTIONS FOR IMPROVING THE SURFACE PROTECTION LINE

1. Implementation of a means of transport, powered by an electromotor
2. Implementation of a crane powered by an electromotor
3. Implementation of automatic regulation, including PLC system and a ladder diagram

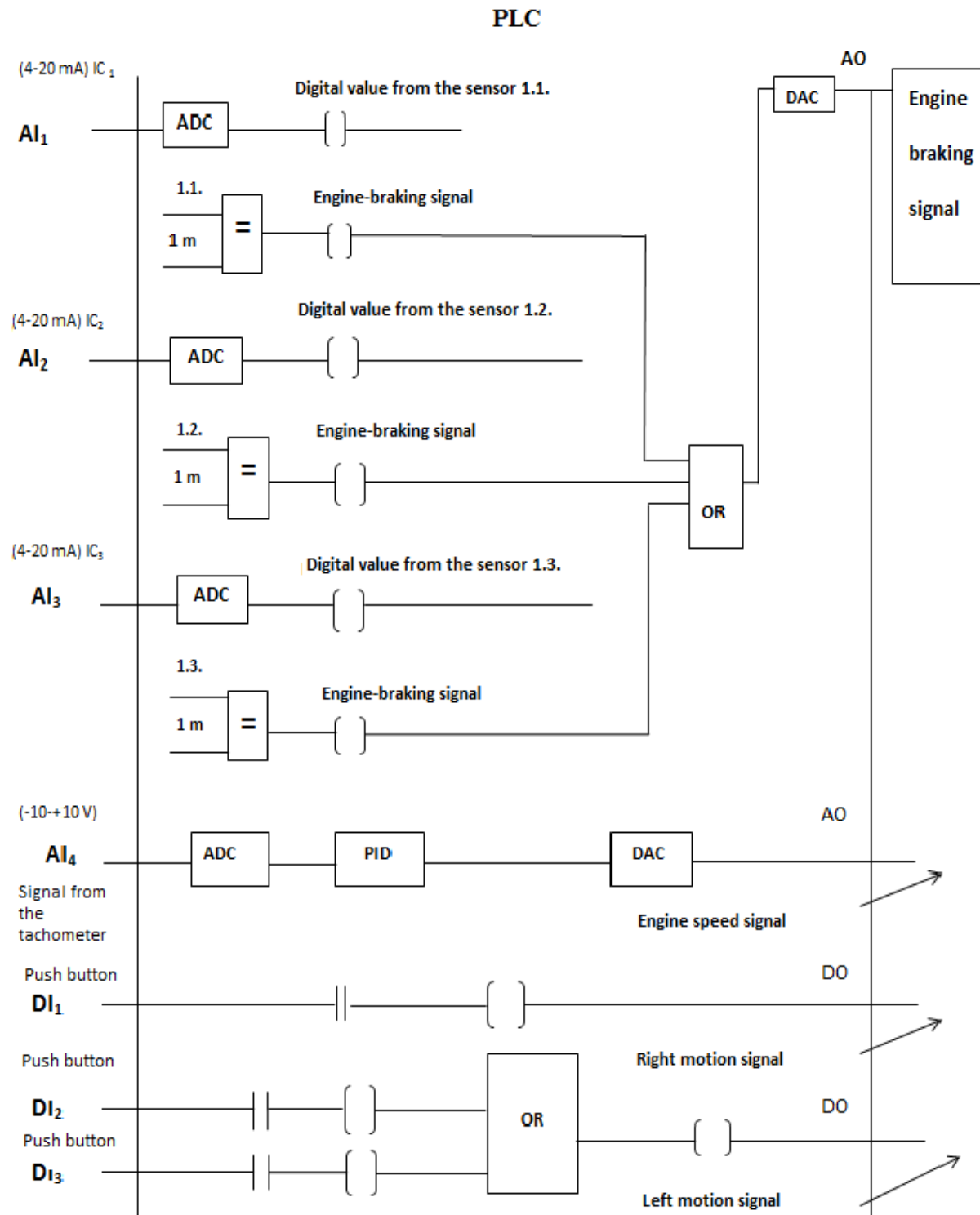

Figure 2. Ladder diagram used for engine manipulation during horizontal movement of the vehicle

PLC system and a ladder diagram, shown in figure 2 in this case are used for engine manipulation during horizontal movement of the vehicle in the line for surface protection. In a ladder diagram for

engine manipulation four analog and three digital inputs are used. Analog input values are received directly from the measuring transducers (sensor). In this case measuring encoders are three infrared sensors and tachometer. The values obtained by the sensor are processed in a program that is written in a PLC system. Since the program works with numerical values in digital form, analog values must be converted. For converting analog values into digital and reverse, A/D and D/A converter are used. Speed in this case is monitored and regulated by a motor driver and a position is regulated by the PLC. Speed loop is closed by a tachometer, which is an integral part of the engine. PLC sets the speed of movement in the form of analog signal in the range from -10 V to 10 V. Speed regulation is done by a PID regulator.

For position control, sensors are needed to detect objects in the environment. In this case, analog infrared sensor is selected. In each cabin, in the line for surface protection, one infrared sensor is set. Analog module accepts the current in the range from 4 mA to 20 mA, where input current of 4 mA is the smallest, and the input current of 20 mA represents a maximum input value. Since the sensors are used to detect objects, the minimum and the maximum current values are joined by the minimum and the maximum distances at which sensors will give an engine-braking signal.

Digital inputs in this case are used to start the engine. It is estimated that the start-engine signal, using the push buttons, gives a worker after completed sand blasting process or painting in one of the cabins, after which will the product be transported to other cabin.

Digital output module provides a connection between PLC and output devices that require an on / off control. The digital output modules operate as switches. Considering the fact that output devices can be motor starters, during the use of digital inputs and outputs, application of the digital output in a ladder diagram is optimal solution.

Table 1. Elements applied in the ladder diagram

Elements for automatic control	Number of elements
Analog infrared sensor	3
Tachometer	1
A/D converter	4
D/A converter	2
PID regulator	1
Push button	3

4. CONCLUSION

Characteristics associated with automated systems are reliability, repeatability, accuracy, independence of human effort and commitment and reduced costs. By designing the system for automation a detailed analysis is needed in order to determine the parts of the production process that could be reasonably automated.

Because of the fact that in the observed company BME serial and individual production are presented at the same time and in parallel flow through the factory processes, it is not realistic to think of applying the full automation of production. Based on the analysis of processes in the given conditions, it was found that the primary problem of the line for surface protection is the current way of handling products and it is necessary to find a new mode of transport and manipulation, which excludes the participation of human labor. The proposed solution involves the introduction of automated electric drives for transport with additional elements such as sensors and PLC system.

5. REFERENCES

- [1] Kompanija BME: <http://www.bme.ba/cms/index.php?proizvodna-tehnologija>
- [2] Bjegović D.: Zaštita metala od korozije, Sveučilište u Zagrebu, 2014
- [3] Perić N., Petrović I., Vašak M.: Procesna automatizacija, Fakultet elektrotehnike i računarstva, Sveučilište u Zagrebu, 2014
- [4] Jurković B.: Elektrimotorni pogoni, Školska knjiga, Zagreb, 1978
- [5] Turajlić S.: Upravljanje u realnom vremenu, Elektrotehnički fakultet u Beogradu, 2014
- [6] Cetinkunt, S.: Mechatronics, John Wiley and Sons Inc., USA, 2007.